

BLOQUE PORTANTE PARA MURO P20

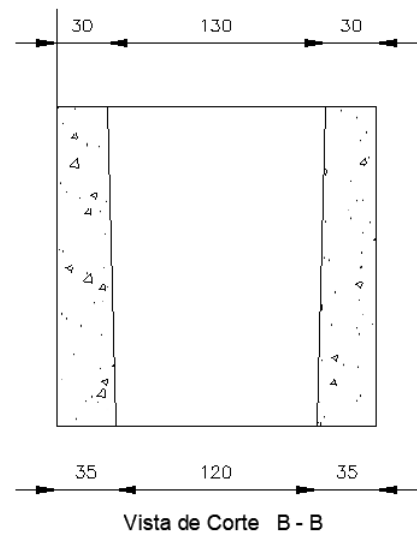

Dimensiones (mm)	190x190x390
Peso Unitario (Kg)	14,8 Kg
Unidades x m2	12,5

Unidades x Pallet	108
Pallets x Equipo	18
Peso x Pallet (Kg)	1570 Kg

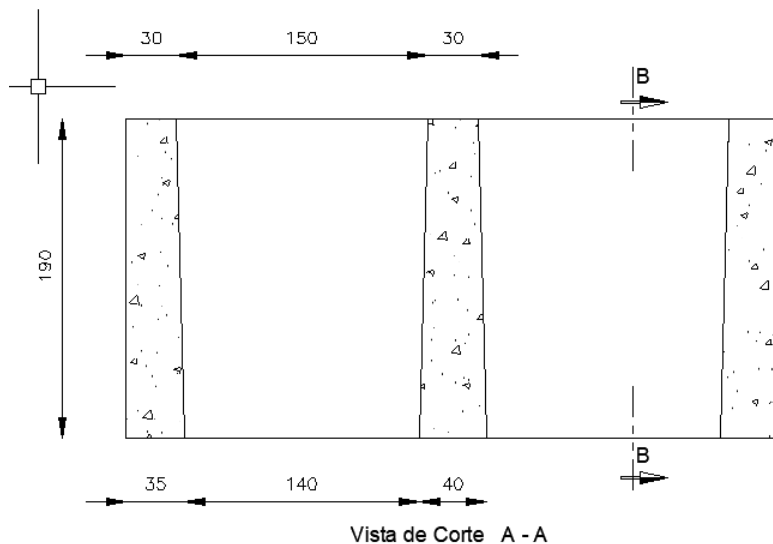
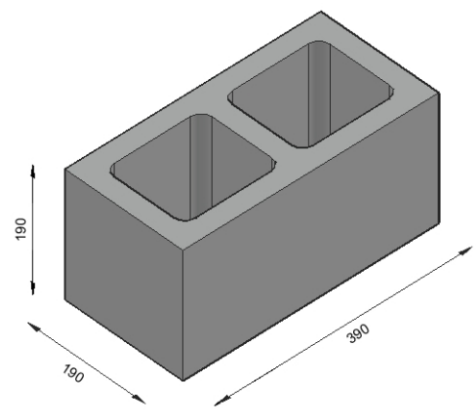
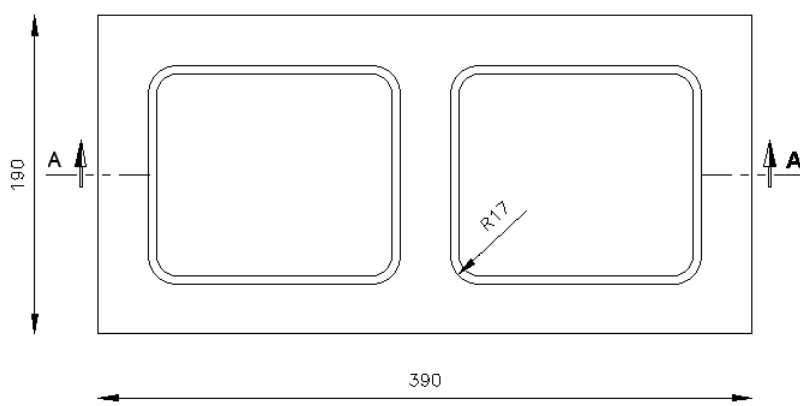

MOSAICOS LANIK S.A.

Planta Industrial | Oficinas comerciales

Autopista Oeste Km.47,350 (1748) Gral. Rodríguez - Buenos Aires

Tel / Whatsapp: 11 5974-1112 | 11 2880-1543 | 11 2324-5304

web: www.mosaicoslanik.com / Email: info@mosaicoslanik.com

